

BXR(LE) Models

Specifications (Brake unit)

Model	Size	Static friction torque T _s [N·m]	Coil (at 20°C)								Heat resistance class	Lead wire		Max. rotation speed [min ⁻¹]	Rotating part moment of inertia J [kg·m ²]	Allowable braking energy E _{ba} [J]	Total braking energy E _t [J]	Armature pull-in time (24 V DC) t _a [s]	Armature release time (7 V DC) t _r [s]	Mass [kg]
			Overexcitation output				Normal excitation output					UL style	Size							
			Voltage [V]	Wattage [W]	Current [A]	Resistance [Ω]	Voltage [V]	Wattage [W]	Current [A]	Resistance [Ω]										
BXR-015-10LE	015	0.06	24	16.5	0.688	35	7	1.4	0.200	35	F	UL3398	AWG26	6000	3.34 × 10 ⁻⁸	5	1000	0.020	0.020	0.03
BXR-020-10LE	020	0.14	24	16.5	0.688	35	7	1.4	0.200	35	F	UL3398	AWG26	6000	5.56 × 10 ⁻⁸	15	3000	0.035	0.020	0.06
BXR-025-10LE	025	0.32	24	16.5	0.688	35	7	1.4	0.200	35	F	UL3398	AWG26	6000	1.56 × 10 ⁻⁷	15	3000	0.035	0.020	0.08
BXR-035-10LE	035	0.62	24	16.5	0.688	35	7	1.4	0.200	35	F	UL3398	AWG26	6000	4.83 × 10 ⁻⁷	87	17000	0.050	0.020	0.12
BXR-040-10LE	040	1.32	24	16.5	0.688	35	7	1.4	0.200	35	F	UL3398	AWG26	6000	6.32 × 10 ⁻⁷	87	17000	0.060	0.020	0.16
BXR-050-10LE	050	3.20	24	16.5	0.688	35	7	1.4	0.200	35	F	UL3398	AWG26	6000	1.51 × 10 ⁻⁶	200	40000	0.060	0.020	0.40

Dimensions (Brake unit)

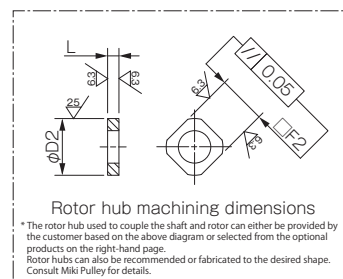
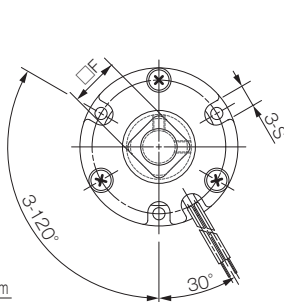
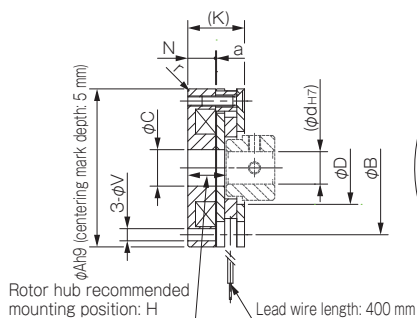

Model	Size	Radial direction dimensions										Axial direction dimensions			Rotor hub machining dimensions		
		A	r	B	C	D	d max.	□F	S	V	H	K	N	a	L	D2	□F2
BXR-015-10LE	015	26	R0.5	22	7	12	6	8	4.3	2.3	9.5 ~ 10.0	14.0	7.0	0.1	4 or more	10 ⁰ _{-0.1}	8 ⁰ _{-0.07}
BXR-020-10LE	020	32	R0.5	28	9	16	8	12	5.0	2.3	9.5 ~ 10.0	14.0	7.0	0.1	4 or more	14 ⁰ _{-0.1}	12 ⁰ _{-0.07}
BXR-025-10LE	025	39	R0.5	33	9	18	8	12	5.5	3.0	9.5 ~ 10.0	14.0	7.0	0.1	4 or more	14 ⁰ _{-0.1}	12 ⁰ _{-0.07}
BXR-035-10LE	035	48	R0.5	42	15	28	14	19	5.5	3.0	9.5 ~ 10.0	14.0	7.0	0.1	4 or more	23 ⁰ _{-0.1}	19 ⁰ _{-0.07}
BXR-040-10LE	040	56	R0.5	50	15	27	14	19	6.5	3.4	9.9 ~ 10.4	14.5	7.4	0.1	4 or more	23 ⁰ _{-0.1}	19 ⁰ _{-0.07}
BXR-050-10LE	050	71	R0.5	65	22	37	20	25	8.0	4.4	14.0 ~ 14.4	19.0	10.5	0.1	4.5 or more	31 ⁰ _{-0.1}	25 ⁰ _{-0.07}

Specifications (Controller)

Model	BEM-24ESN7-120N			
Input voltage	24V DC ± 10% smoothing power supply			
Output voltage	Initial: 24 V DC (0.2 sec.) Constant: 7 V DC (± 10%), PWM control * When the input voltage is 21 V DC, the output voltage is cut off.			
Max. output current	1.0 A DC (ambient temp.: 20° C), 0.8 A DC (ambient temp.: 60° C)			
Time rating	Continuous			
Insulating resistance	500 V DC, 100 M Ω with Megger (input/output - between terminal and case)			
Dielectric strength voltage	1000 V AC, 50/60 Hz, 1 min. (input/output - between terminal and case)			
Ambient environment	-20 to 60° C, 5 to 95% RH, no condensation/freezing			
Mass	0.02kg			
Lead wire	Function	Description	UL style	Size
Red	Input (+)	Connects the 24 V DC smoothing power supply (+)	UL3398	AWG26
Black	Input (-)	Connects the 24 V DC smoothing power supply (-)	UL3398	AWG26
Blue	Output	Connects the spring-actuated brake (either pole)	UL3398	AWG26
Blue	Output	Connects the spring-actuated brake (either pole)	UL3398	AWG26

Dimensions (Controller)

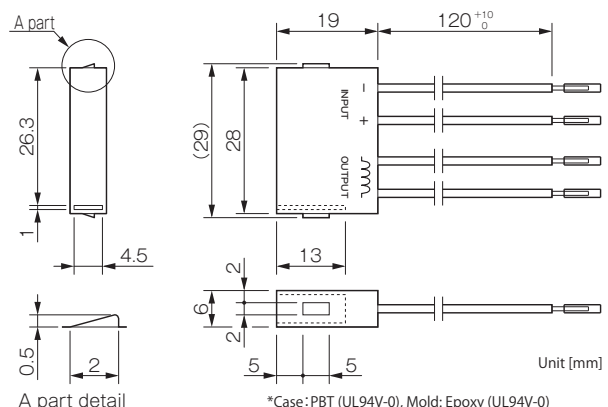

Structure (Controller)

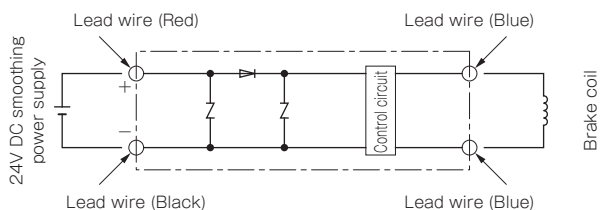

Timing Chart (Controller)

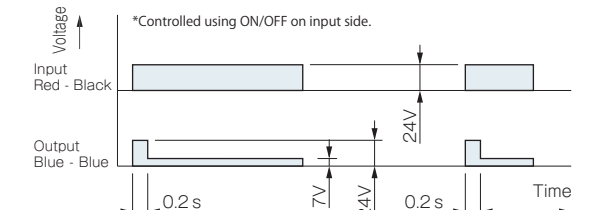

Options Rotor Hub

■ Set screw type (C)

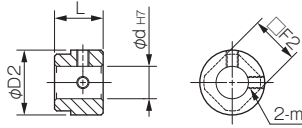

Unit [mm]

Model	Size	L	D2	□ F2	m Nominal dia.	d		
						Standard	Min.	Max.
BXR-015-10LE	015	10	10	8 ⁰ _{-0.07}	M2.5	5	4	5
BXR-020-10LE	020	10	14	12 ⁰ _{-0.07}	M3	8	5	8
BXR-025-10LE	025	10	16	12 ⁰ _{-0.07}	M3	8	5	8
BXR-035-10LE	035	12	26	19 ⁰ _{-0.07}	M4	14	8	14
BXR-040-10LE	040	12	26	19 ⁰ _{-0.07}	M4	14	11	14
BXR-050-10LE	050	15	35	25 ⁰ _{-0.07}	M5	20	15	20

■ Press fit type (P)

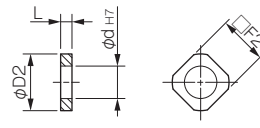

Unit [mm]

Model	Size	L	D2	□ F2	d		
					Standard	Min.	Max.
BXR-015-10LE	015	4	9.5	8 ⁰ _{-0.07}	5	5	6
BXR-020-10LE	020	4	14	12 ⁰ _{-0.07}	8	7	8
BXR-025-10LE	025	4	14	12 ⁰ _{-0.07}	8	7	8
BXR-035-10LE	035	4	23	19 ⁰ _{-0.07}	14	9	14
BXR-040-10LE	040	4	23	19 ⁰ _{-0.07}	14	11	14
BXR-050-10LE	050	4.5	31	25 ⁰ _{-0.07}	20	15	20

How to Place an Order

BXR-015-10LE-006-C5

Size ——— Bore diameter (dimension symbol: d)
 Controller set type ——— Option (Rotor Hub)
 Nominal static friction torque (3-digit number listed in the specifications tables) ——— Blank: No rotor hub
 C: Set screw type
 P: Press fit type

Items Checked for Design Purposes

I Precautions for Handling

■ Brakes

Electromagnetic brakes use many soft materials. Care should be taken during handling as accidentally striking, dropping or applying excessive force to the brake could cause denting or deformation.

■ Lead wires

Be careful not to pull excessively on the brake lead wires, bend them at sharp angles or allow them to hang too low.

■ Friction Surfaces

Since these are dry brakes, they must be used with the friction surfaces dry. Keep water and oil away from the friction surfaces when handling the brakes.

I Precautions for Use

■ Holding use

These brakes are holding brakes. Do not use them for ordinary braking, except for emergency braking in the event of a power outage or the like.

■ Environment

These brake units are dry braking systems, meaning that the torque will drop if oil residue, moisture, or other liquids get onto friction surfaces. In addition to friction surfaces, lead wires are not oil resistant. Lead wire covers may deteriorate noticeably in environments exposed to oil, cutting oil, etc.

■ Operating Temperature

The operating temperature range is -10° C to 40° C for brakes and -20° C to 60° C for dedicated controllers. If you will use the product at other temperatures, consult Miki Pulley.

■ Power Supply Voltage Fluctuations

Full braking performance may not be guaranteed with extreme fluctuations in power supply voltage. Keep the power supply voltage to within ± 10% of the rated voltage.

■ Air Gap Adjustment

BXR(LE) models do not require air gap adjustment. The brake air gap is adjusted at shipment from the factory.

■ Circuit Protectors

Circuit protectors should not be connected as they are built into the dedicated controllers.

■ Controller Operation

The control function is operated by the ON/OFF switch on the input side, so switching should be carried out by the input side of the dedicated controller.

I Precautions for Mounting

■ Affixing the Rotor Hub

In the design, the rotor hub section should be installed such that it does not touch the armature or stator. Also, with the normal installation method of using hexagon-socket set screws coated with adhesive, take care not to trap adhesive between the screws and the rotor hub surface.

■ Mounting the Brake

Implement screw-locking measures such as use of an adhesive thread locking compound to bolts and screws used to install brakes. If using a spring washer to prevent loosening, use a conical spring washer, and ensure that it does not contact the armature.

■ Shafts

The shaft tolerance should be h7 class (JIS B 0401). If using an optional press-fit type rotor hub, we recommend that the shaft tolerance be a press-fit tolerance of r6 class (JIS B 0401).

■ Accuracy of Brake Attachment Surfaces

Make sure that the centering mark and shaft concentricity (X) and the shaft perpendicularity (Y) relative to the brake mounting surface do not exceed the allowable values in the table below.

Model	Size	Concentricity (X) T.I.R. [mm]	Perpendicularity (Y) T.I.R. [mm]
BXR-015-10LE	015	0.05	0.02
BXR-020-10LE	020	0.05	0.02
BXR-025-10LE	025	0.05	0.02
BXR-035-10LE	035	0.05	0.02
BXR-040-10LE	040	0.10	0.02
BXR-050-10LE	050	0.10	0.02

